

# DYNAPAC STATIC ROLLER



The generation six of Dynapac CS1400 VI



# STATIC COMPACTION AT ITS BEST

**THE DYNAPAC CS1400 VI STATIC ROLLER** is a modern, articulated three-drum roller with the same static linear load and drum diameter on all drums. The roller covers the asphalt mat with its full width. The CS1400 VI roller is used primarily to compact asphalt when the course has a typical thickness of up to 50 mm, depending on the stiffness of the asphalt compound and the prevailing weather conditions.

The machine is suitable for medium-size and large-size applications. It is ideal for use in areas where the ground should not be vibrated, such as in areas close to old buildings and on bridges.

The operators station is based on the asphalt roller generation VI platform with ROPS and cab versions that gives very good visibility and ergonomics for the roller operator.



## LOW EMISSIONS AND FUEL CONSUMPTION

The Dynapac CS1400 VI has ample power resources and fulfils Stage V/ T4 final emission regulations. For markets not having the ultra low sulfur diesel fuel there is also a stage IIIA engine alternative available. Both engine alternatives got an ECO-position on the throttle control that keeps fuel consumption and noise at a low level. Automatic idling is also standard.

## SERVICE FRIENDLY

The engine is easily accessed, as it is placed between the front drums under a large fully openable engine hood and service points like engine oil check, battery plus fuel filters are placed within easy reach in front of the cooler.

## ROLLER OPERATORS IN MIND

The swiveling operator's module allows a 180° (+/- 90°) turn of seat, instruments and levers, keeping the operator in full control. It can also slide from side to side for best visibility and ergonomics. Four different cabs and one ROPS platform gives a flexibility to adapt to all markets needs

## FLEXIBLE BALLAST SYSTEM

Flexible water ballast system with variable static linear load.

Front drums: 50 kg/cm to 59 kg/cm  
Rear drum: 46 kg/cm to 58 kg/cm

## RELIABLE BRAKE SYSTEM

The Dynapac CS1400 VI features the same reliable safety brakes as other Dynapac rollers. The brakes are automatically engaged on all three drums in the event of engine malfunction or hydraulic failure. In addition, the reserve/parking brake button on the instrument panel is easily accessible as the instrument panel follows the seat and steering module.

## ALL EQUAL LOAD

The equal static linear load on the three drums and the centre point articulation makes it possible to calculate with the full 2100 mm compaction width all the time. This gives up to 50% more capacity compared with old pivot steered concepts. The 50% higher capacity means 50% lower fuel consumption and 50% less working time needed.

## HIGHLY EFFICIENT SPRINKLER SYSTEM

- Fully wind protected sprinkler bars.
- AWC, Automatic Water Control.
- Max flow sprinkler button.
- Sprinkler timer and water level gauge.
- Dual sprinkler bars visible from operators station.
- Central water tank filling left & right side.
- Dual "Heavy Duty" sprinkler pumps, 3-stage filtering.
- Anti-freeze connection in sprinkler system.





## DYNAPAC CS1400 VI



*Driven rear drum with same large diameter as the front drums. Equal static linear load over the whole machine width.*

*The sprinkler system is pressurised, with two separate pumps, back-up function, and filtering of the water. The high-resistant plastic water tanks have large filling openings for quick and easy filling from ground level. The entire sprinkler system is made of non-corrosive material to ensure high reliability and to prevent adhesion. A sprinkler timer is available as an option.*

*Articulated centre pivot steering ensures proper drum over-lapping even when turning or changing lanes.*







The swiveling operator's module allows a 180° (+/- 90°) turn of seat, instruments and levers, keeping the operator in full control. It can also slide from side to side for best visibility and ergonomics.

Four different cabs and one ROPS platform gives a flexibility to adapt to all markets needs.

The engine is easily accessed, as it is placed between the front drums under a large fully openable engine hood and service points like engine oil check, battery plus fuel filters are placed within easy reach in front of the cooler.

Two driven front drums with large diameter provides best traction and eliminates shoving of material.

# YOU'RE IN CONTROL

## ELECTRIC DRIVE CONTROL

When working mode is activated the Electronic Drive Control will give 'soft' starting and stopping to prevent bowing or cracking in the asphalt layers; allowing even unskilled roller operators to start and stop without leaving marks. The working mode will also make it possible to use the drum vibration and drum off-set function.

As a safety feature, the machine will drop out of the 'soft' mode and brake immediately if the lever is moved quickly, signalling the need for a quick stop.

The maximum speed is set with the turning knob potentiometer and there are two different gears to be set with a toggle switch. Gear 1 is for hilly areas and gear 2 is for normal conditions. In the display you see which gear you have chosen.



## TOUCH SCREEN DISPLAY

Full color 7 inch (180 mm) display with all vital working and compaction information comes up when you push the "Home" button.

The display is of touch screen type but can also be worked from the display controller.

Even though a touch screen is very practical it could sometimes be useful to have the display controller as an alternative especially if you are working with hand gloves.

### Smooth start and stop prevents shuffling



Main menu

Back

Display controller



# BEST COMPACTION PERFORMANCE

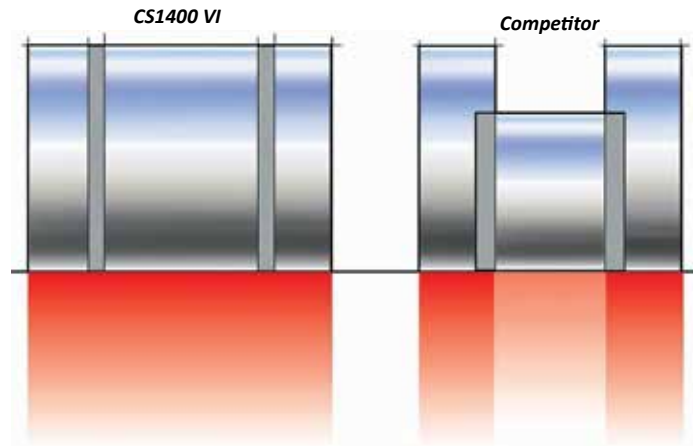
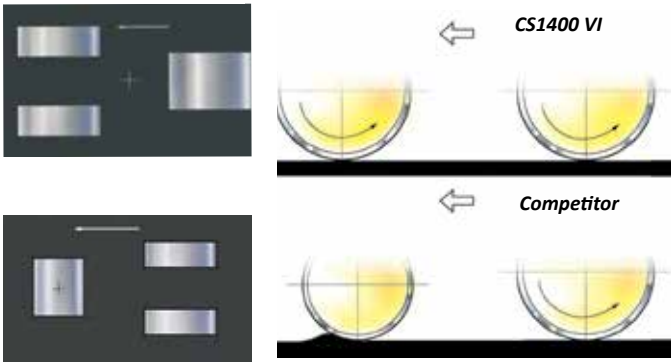

## ALL-WHEEL DRIVE

Propulsion on all three drums provides excellent gradeability and eliminates shoving of the material. The large drum diameters and smooth drum edges enhance rolling performance and compaction effect. Large diameter also virtually eliminates the bow wave problem and risk of surface cracks.

## EQUAL STATIC LINEAR LOAD ON ALL DRUMS

In static compaction, balance is a crucial matter. The Dynapac CS1400 VI presents perfect weight balance and matching drum width front and rear. The result is equal static linear load on all three drums. Large and equal drum diameter front and rear ensures uniform compaction effort across the entire machine width.

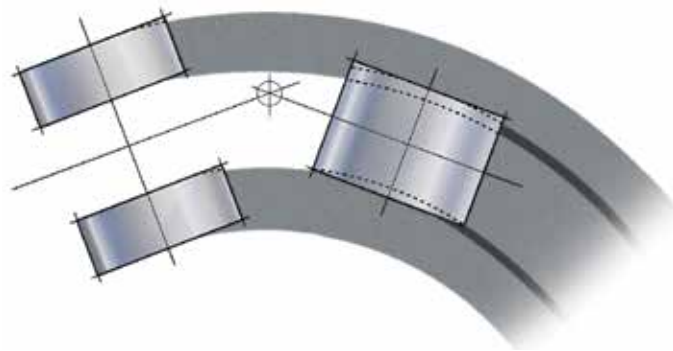

## CENTRE-POINT ARTICULATION

The Dynapac CS1400 VI features small inside/outside turning radius, and vertical oscillating articulation. Articulated centre-pivot steering gives proper drum overlap and equal force over the entire rolling width, also when turning or changing lanes.



## TECHNICAL DATA

		CS1400 VI
Operating mass (incl. ROPS, without ballast)		10 600 kg
Max. operating mass (incl. ROPS, ballasted)		12 800 kg
Max. front module mass (incl. ROPS, ballasted)		6700 kg
Max. rear module mass (incl. ROPS, ballasted)		6100 kg
Static linear load (incl. ROPS, without / with ballast)	Front: 50/59 kg/cm Rear: 46/58 kg/cm	
Speed		0-15 km/h
Propulsion		Three Drums
Water tank		510 litre
Compaction width		2100 mm
Drum diameter		1500 mm
Length		4850 mm
Width		2100 mm
Height, with cab or ROPS		2995 mm

## Engine

Model	
Deutz TD 3.6 V/T4f	Rated power, ISO 14396, 55 kW (74 hp) @ 2200 rpm
Deutz TD 3.6 IIIA	Rated power, ISO 14396, 55 kW (74 hp) @ 2300 rpm



## STANDARD EQUIPMENT

Automatic Water Control (AWC)	Fail safe brakes
Back up alarm	Filters for sprinkler system
Battery switch	Horn
Brake release	Hydraulic checkpoints
Cup and can holder	Ignition key
Display engine temperature meter	Instrument cover lockable (not cab)
Display fuel level	Interlock
Display hour meter	Lifting points
Display hydraulic fluid temperature	Operators platform, shock mounted
Display speedometer	Operators platform, swivelling and sliding operators station
Display tachometer	Parking brake
Display voltage meter	Rear view mirr, Process view (standard for cab machines, option for ROPS machines)
Display water level gauge	Seat belt 3", retractable
DYN@LINK Advanced	Sprinkler bars wind protection
Electronic Drive Control	
Emergency stop	

Sprinkler extra flow button
Sprinkler system pressurized
Sprinkler system back-up with dual pumps and 6 sprinkler bars
Sprinkler timer
Springloaded scrapers
Steering wheel tiltable
Warning air cleaner
Warning brake
Warning engine temperature
Warning engine oil pressure
Warning clogged hydraulic fluid filter
Warning hydraulic fluid temperature
Warning low charge
Warning low fuel level
Tie down points

## OPTIONAL EQUIPMENT

Asphalt T Meter dual sensors
Certificate, SBF 127
Hydraulic fluid, bio
Decal, risk location
Edge press, front mounted
Environmental Cert (Swedish)
Extra set of user instructions
Fire extinguisher
First aid box
Hearing protector
JointCutD, 80 mm
JointCutD, 150 mm
Lights, driv. RH traffic
Lights, driv. LH traffic
Lights Direct side mount (driving lights required)
Lights, hazard warning (comes with driving lights)
Lights, license plate (driving lights required)

**Your Partner on the Road Ahead**



**Dynapac Compaction Equipment AB**  
 Industrivägen 2, 371 31 Karlskrona, Sweden  
 Phone: +46 455 30 60 00 - Fax: +46 455 30 60 30  
[www.dynapac.com](http://www.dynapac.com)