

Technical Data

ENGINE

Manufacturer
Mercedes Benz (MTU)

Model
OM473LA (MTU 6R 1500)

Configuration
Inline 6, turbocharged and intercooled.

Gross Power
430 kW (577 hp) @ 1 700 rpm

Net Power
405 kW (543 hp) @ 1 700 rpm

Gross Torque
2 750 Nm (2 028 lbf) @ 1 300 rpm

Displacement
15,6 litres (952 cu.in)

Auxiliary Brake
Engine Valve Brake

Fuel Tank Capacity
494 litres (130 US gal)

AdBlue® Tank Capacity
40 litres (11 US gal)

Certification
OM473LA (MTU 6R 1500) meets EU Stage V emissions regulations.

TRANSMISSION

Manufacturer
Allison

Model
4800 ORS

Configuration
Fully automatic planetary transmission

Layout
Engine mounted

Gear Layout
Constant meshing planetary gears, clutch operated

Gears
7 Forward, 1 Reverse

Clutch Type
Hydraulically operated multi-disc

Control Type
Electronic

Torque Control
Hydrodynamic with lock-up in all gears.

TRANSFER CASE

Manufacturer
Kessler

Series
W2400

Layout
Remote mounted

Gear Layout
Three in-line helical gears

Output Differential
Interaxle 29/71 proportional differential. Automatic inter-axle differential lock.

AXLES

Manufacturer
Front - Bell
Rear - Kessler

Model
Front: 30T
Rear: 71T

Differential
Front: High input controlled traction differential with spiral bevel gears

Rear: Centre input open differential with spiral bevel gears

Final Drive
Outboard heavy duty planetary on all axles.

BRAKING SYSTEM

Service Brake
Dual circuit, full hydraulic actuation wet disc brakes on front and rear axles. Wet brake oil is circulated through a filtration and cooling system.

Maximum brake force:
437 kN (98 242 lbf)

Park & Emergency
Spring applied, air released driveline mounted disc.

Maximum brake force:
379 kN (85 203 lbf)

Auxiliary Brake

Automatic engine valve brake. Automatic retardation through electronic activation of wet brake system.

Total Retardation Power
Continuous: 574 kW (770 hp)
Maximum: 983 kW (1 318 hp)

WHEELS

Type
Radial Earthmover

Tyre
Front: 875/65 R29
Rear: Twin 24.00 R35

FRONT SUSPENSION

Semi-independent, leading A-frame supported by hydro-pneumatic suspension struts. Suspension is electronically controlled adaptive suspension with ride height adjustment.

REAR SUSPENSION

Trailing arm cradle supported by hydro-pneumatic suspension struts, with an additional lateral stabiliser.

HYDRAULIC SYSTEM

Full load sensing system serving the prioritized steering, body tipping, suspension and brake functions. A ground-driven, load sensing emergency steering pump is integrated into the main system.

Pump Type
Variable displacement load sensing piston

Flow
330 L/min (87 gal/min)

Pressure
250 bar (3 626 psi)

Filter
5 microns

STEERING SYSTEM

Double acting cylinders, with ground-driven emergency steering pump.

Lock to lock turns
4,9

Steering Angle
42°

DUMPING SYSTEM

Two double-acting, two stage telescopic, dump cylinders.

Raise Time
17 seconds

Lowering Time
18 seconds

Tipping Angle
55 deg standard, or any lower angle programmable

PNEUMATIC SYSTEM

Air drier with heater and integral unloader valve, serving park brake and auxiliary functions.

System Pressure
810 kPa (117 psi)

ELECTRICAL SYSTEM

Voltage
24 V

Battery Type
Two AGM (Absorption Glass Mat) type.

Battery Capacity
2 X 75 Ah

Alternator Rating
28V 80A

MAX. VEHICLE SPEED

	4 km/h	2,5 mph
1st	4 km/h	2,5 mph
2nd	8 km/h	5,6 mph
3rd	16 km/h	10,6 mph
4th	21 km/h	13,7 mph
5th	30 km/h	20 mph
6th	41 km/h	27 mph
7th	47 km/h	32 mph
R	6 km/h	4 mph

CAB

ROPS/FOPS certified 77 dBA internal sound level measured according to ISO 6396.

Load Capacity & Ground Pressure

OPERATING WEIGHTS		GROUND PRESSURE*		LOAD CAPACITY		OPTION WEIGHTS	
UNLADEN	kg (lb)	LADEN		BODY	m ³ (yd ³)	kg (lb)	
Front	20 211 (44 558)	(No sinkage/Total Contact Area Method)		Struck Capacity	27 (35,3)	Bin liner	1 116 (2 460)
Rear	22 265 (49 086)	875/65 R29	kPa (Psi)	SAE 2:1 Capacity	35 (45,8)	Tailgate	1 516 (3 342)
Total	42 476 (93 644)	Front	333 (48)	SAE 1:1 Capacity	42 (54,9)	EXTRA WHEELSET	
				SAE 2:1 Capacity		875/65 R29	1 024 (2 258)
LADEN		24.00 R35	kPa	with Tailgate	35,6 (46,6)	24.00 R35	1 240 (2 734)
Front	26 811 (59 108)	Rear	469 (68)	Rated Payload	55 000 kg		
Rear	70 665 (155 768)				(121 254 lb)		
Total	97 476 (214 898)						

* Front ground pressure calculated with Michelin XAD65-1 tyre. Rear ground pressure calculated with Michelin XDT B tyre.

Dimensions

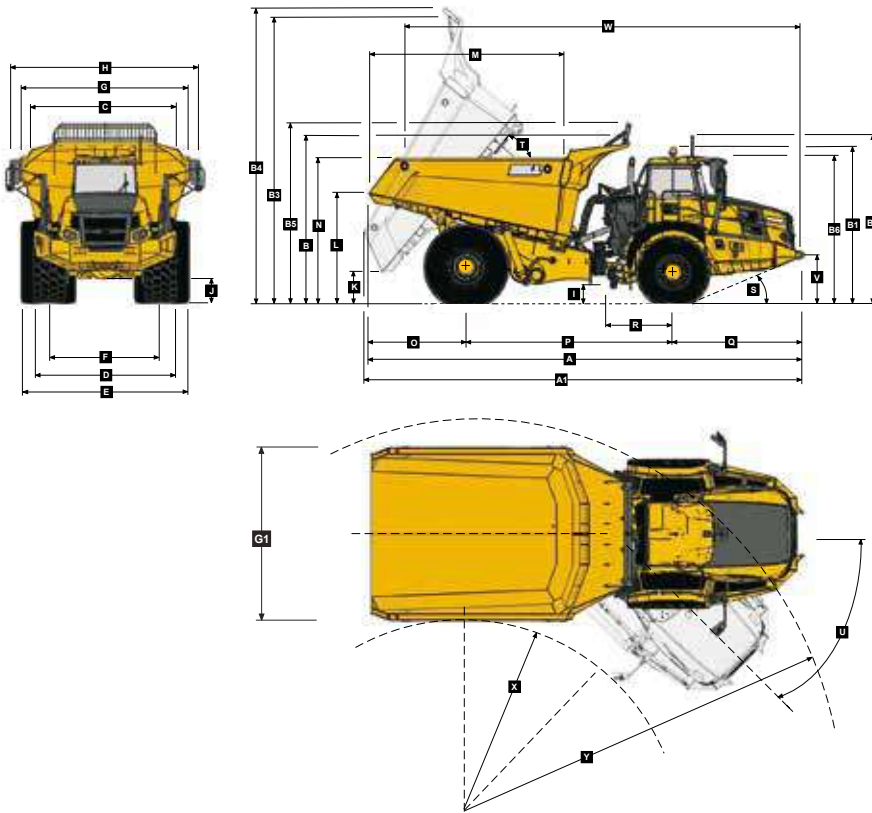

Machine Dimensions

A	Length - Transport Position	11 114 mm (36 ft. 6 in.)
A1	Length - Bin Fully Tipped	11 178 mm (36 ft. 8 in.)
B	Height - Transport Position w/o Rock Guard	4 209 mm (13 ft.10 in.)
B	Height - Transport Position with Rock Guard	4 212 mm (13 ft.10 in.)
B1	Height - Rotating Beacon	4 050 mm (13 ft. 3 in.)
B2	Height - Load Light	4 333 mm (14 ft. 2 in.)
B3	Bin Height - Fully Tipped w/o Rock Guard	7 476 mm (24 ft. 6 in.)
B4	Bin Height - Fully Tipped with Rock Guard	7 692 mm (25 ft. 3 in.)
B5	Height - Rock Guard Operating Position	4 675 mm (15 ft. 4 in.)
B6	Height - Cab	3 813 mm (12 ft. 6 in.)
C	Width over Mudguards	3 790 mm (12 ft. 5 in.)
D	Width over Tyres - Front - 875/65 R29	3 832 mm (12 ft. 7 in.)
E	Width over Tyres - Rear - 24.00R35	4 444 mm (14 ft. 7 in.)
F	Tyre Track Width - Front	2 949 mm (9 ft. 8 in.)
F	Tyre Track Width - Rear	2 992 mm (9 ft. 10 in.)
G	Width over Bin	4 487 mm (14 ft. 9 in.)
G1	Width over Tailgate	4 800 mm (15 ft. 9 in.)
H	Width over Mirrors - Operating Position	5 242 mm (17 ft. 2 in.)
I	Ground Clearance - Artic	561 mm (22.09 in.)
J	Ground Clearance - Front Axle	554 mm (21.81 in.)
K	Ground Clearance - Bin Fully Tipped	851 mm (33.5 in.)
L	Bin Lip Height - Transport Position	2 952 mm (9 ft. 8 in.)
M	Bin Length	5 036 mm (16 ft. 6 in.)
N	Load over Height	3 824 mm (12 ft. 7 in.)
O	Rear Axle Centre to Bin Rear	2 477 mm (8 ft. 2 in.)
P	Rear Axle Centre to Front Axle Centre	5 285 mm (17 ft. 4 in.)
Q	Front Axle Centre to Machine Front	3 352 mm (11 ft.)
R	Front Axle Centre to Artic Centre	1 558 mm (5 ft. 1 in.)
S	Approach Angle	22°
T	Maximum Bin Tip Angle	55°
U	Maximum Articulation Angle	42°
V	Front Tie Down Height	1 263 mm (4 ft. 2 in.)
W	Machine Lifting Centres	10 116 mm (33 ft. 2 in.)
X	Inner Turning Circle Radius	4 246 mm (13 ft.11 in.)
Y	Outer Turning Circle Radius	9 216 mm (30 ft. 3 in.)

Gradeability/Rimpull

- Determine tractive resistance by finding intersection of vehicle mass line and grade line.
NOTE: 2% typical rolling resistance is already assumed in chart and grade line.
- From this intersection, move straight right across charts until line intersects rimpull curve.
- Read down from this point to determine maximum speed attained at that tractive resistance.

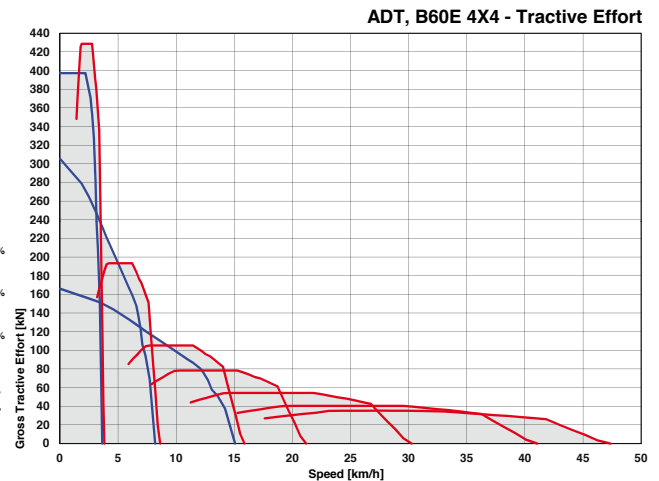
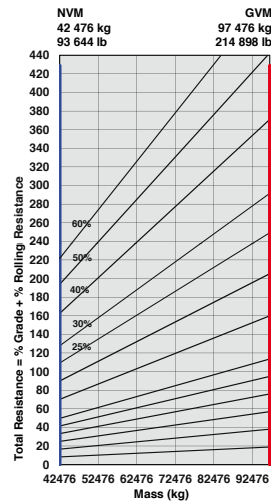

Retardation

- Determine retardation force required by finding intersection of vehicle mass line.
- From this intersection, move straight right across charts until line intersects the curve.
NOTE: 2% typical rolling resistance is already assumed in chart.
- Read down from this point to determine maximum speed.

